

USA office: Fontana **ITA** office: Milano **AUS** office: Truganina **POL** office: Gdańsk
DEU office: FDS GmbH, Neuer Höltigbaum 30, 22143 Hamburg, Deutschland
GBR office: FDS Corporation Limited, Unit 4, Blackacre Road, Great Blakenham,
Ipswich, IP6 0FL, United Kingdom **FRA** office: Saint Vigor d'Ymonville

Outdoor Pop-Up Canopy
Outdoor Pop-up-Pavillon
Auvent Extérieur Escamotable
Pabellón Emergente para Exteriores
Tettoia Pop-Up da Esterno
Pawilon zewnętrzny
Pop-up Luifel voor Buiten

NP12823

THIS INSTRUCTION BOOKLET CONTAINS **IMPORTANT** SAFETY INFORMATION.
PLEASE READ AND KEEP FOR FUTURE REFERENCE.

EN



Before You Start

- ⚠ Please read all instructions carefully.
- ⚠ Retain instructions for future reference.
- ⚠ Separate and count all parts and hardware.
- ⚠ Read through each step carefully and follow the proper order.
- ⚠ We recommend that, where possible, all items are assembled near to the area in which they will be placed in use, to avoid moving the product unnecessarily once assembled.
- ⚠ Always place the product on a flat, steady and stable surface.
- ⚠ Keep all small parts and packaging materials for this product away from babies and children as they potentially pose a serious choking hazard.

DE



Vor dem Beginnen

- ⚠ Bitte lesen Sie alle Anweisungen sorgfältig durch.
- ⚠ Bewahren Sie die Anweisungen zur zukünftigen Verwendung auf.
- ⚠ Überprüfen Sie, ob alle Teile und Zubehörteile vorhanden sind.
- ⚠ Lesen Sie jeden Schritt sorgfältig durch und befolgen Sie die richtige Reihenfolge.
- ⚠ Wir empfehlen, alle Teile möglichst in der Nähe des Aufstellungsortes zu montieren, um unnötige Bewegungen nach der Montage zu vermeiden.
- ⚠ Stellen Sie den Artikel immer auf eine ebene, feste und stabile Fläche.
- ⚠ Halten Sie alle kleinen Teile und Verpackungsmaterialien fern von Babys und Kindern, ansonsten besteht Erstickengefahr.

FR



Avant de Commencer

- ⚠ Veuillez lire attentivement toutes les instructions.
- ⚠ Conservez les instructions pour vous y référer ultérieurement.
- ⚠ Vérifiez toutes les pièces et les accessoires.
- ⚠ Lisez attentivement chaque étape et suivez l'ordre correct.
- ⚠ Nous recommandons que, dans la mesure du possible, tous les produits soient assemblés à proximité de la zone où ils seront utilisés, afin d'éviter tout déplacement inutile du produit une fois assemblé.
- ⚠ Placez toujours le produit sur une surface plane et stable.
- ⚠ Conservez toutes les petites pièces de ce produit et les matériaux d'emballage hors de portée des bébés et des enfants, car ils pourraient présenter un risque d'étouffement.

ES



Antes de Empezar

- ⚠ Lea atentamente todas las instrucciones.
- ⚠ Conserve las instrucciones para futuras consultas.
- ⚠ Separe y cuente todas las piezas y los accesorios.
- ⚠ Lea detenidamente cada paso y siga el orden correcto.
- ⚠ Recomendamos que, siempre que sea posible, todos los elementos se monten cerca de la zona en la que se van a utilizar, para evitar mover el producto innecesariamente una vez montado.
- ⚠ Coloque siempre el producto sobre una superficie plana, estable y firme.
- ⚠ Mantenga todas las piezas pequeñas y los materiales de embalaje de este producto lejos de los bebés y los niños, ya que pueden representar un grave riesgo de asfixia.

IT



Prima di Iniziare

- ⚠ Si prega di leggere attentamente tutte le istruzioni.
- ⚠ Conservare le istruzioni per riferimento futuro.
- ⚠ Separare e contare tutte le parti e gli accessori.
- ⚠ Leggere attentamente ogni passo e seguire l'ordine corretto.
- ⚠ Si consiglia, ove possibile, di assemblare tutti gli articoli vicino alla zona in cui verranno posti in uso, per evitare di spostare inutilmente il prodotto una volta assemblato.
- ⚠ Posizionare sempre il prodotto su una superficie piana, stabile.
- ⚠ Tenere tutte le piccole parti e i materiali di imballaggio di questo prodotto lontano dalla portata di neonati e bambini, in quanto possono costituire un serio pericolo di soffocamento.

PL



Zanim Zacziesz

- ⚠ Zapoznaj się z instrukcją.
- ⚠ Zachowaj instrukcję do wglądu.
- ⚠ Posortuj części i upewnij się, że zestaw jest kompletny.
- ⚠ Zapoznaj się ze sposobem montażu i postępuj zgodnie z instrukcją.
- ⚠ Zalecamy, aby montaż odbywał się możliwie najbliżej miejsca docelowego położenia produktu, aby uniknąć niepotrzebnego przesuwania.
- ⚠ Upewnij się, że produkt znajdzie się na płaskiej i stabilnej powierzchni.
- ⚠ Upewnij się, że materiały wykorzystane podczas pakowania produktu oraz jego elementy znajdują się poza zasięgiem dzieci.

NL



Voordat U Begint

- ⚠ Lees alstublieft alle instructies zorgvuldig door.
- ⚠ Bewaar de instructies voor toekomstig gebruik.
- ⚠ Scheid en tel alle onderdelen en beslag.
- ⚠ Lees elke stap zorgvuldig door en volg de juiste volgorde.
- ⚠ Wij raden aan om, waar mogelijk, alle items te monteren in de nabijheid van de plaats waar ze zullen worden gebruikt, om onnodige verplaatsing van het product na montage te voorkomen.
- ⚠ Plaats het product altijd op een vlak, stabiel en stevig oppervlak.
- ⚠ Houd alle kleine onderdelen en verpakkingsmaterialen van dit product buiten bereik van baby's en kinderen omdat ze een ernstig verstikkingsgevaar kunnen vormen.

Parts List

#A X1



Frame (See details below)

#B X1

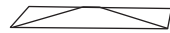

Roof cover

#C-1 X1



Side wall

#C-2 X2

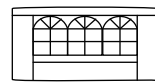

Sidewall with window

#D X1



Roller bag

#E X4



Tie-down rope

#F X4



Sandbag

#G X8



Stake

#4 X1 set
(Male pole & female pole)

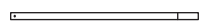

Awning pole

#5 X2



Single wing awning support pole

#7 X1 pack (Twist-type screw & Leg clamp*2)

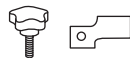

Plastic connector

Assembly Instruction

1

Take out the pre - assembled frame, grasp the two outer legs, lift the frame slightly off the ground, and then pull the frame open while stepping backward.

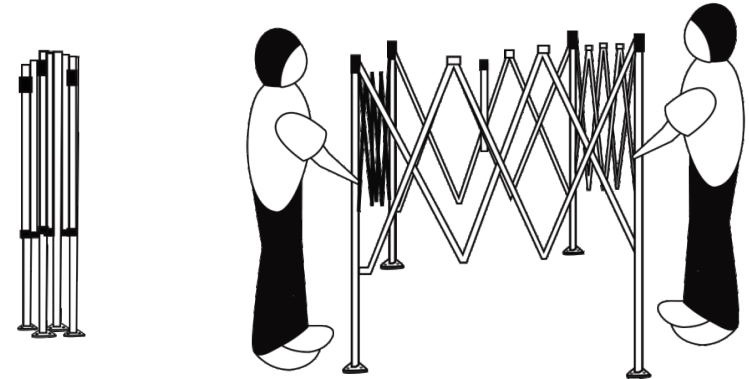

2

Attach the roof cover to the frame, and then fully unfold the frame.

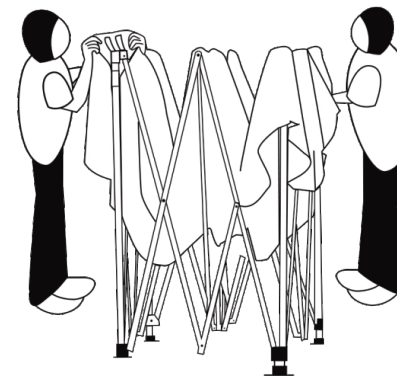

Secure the Velcro on the cover to the Velcro on each leg pole.

3

Lock the leg poles by pushing up the crossbars until you hear the upper buttons click.

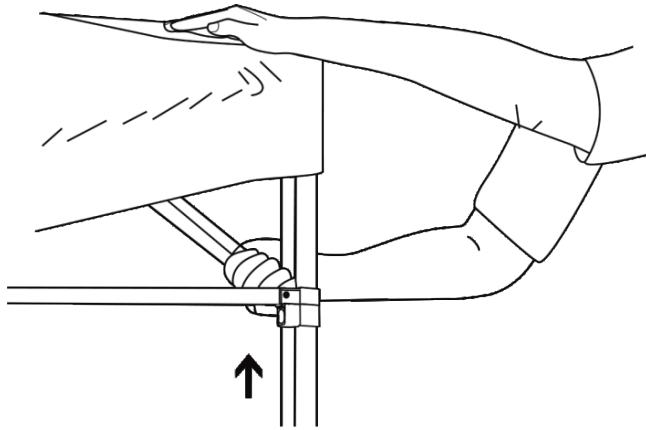

4

Attach the awning to the cover using Velcro.

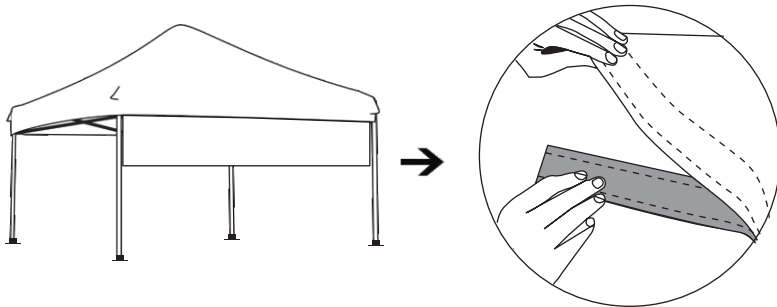

Awning installation:

1

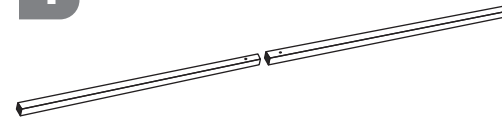

Connect the awning pole.

2

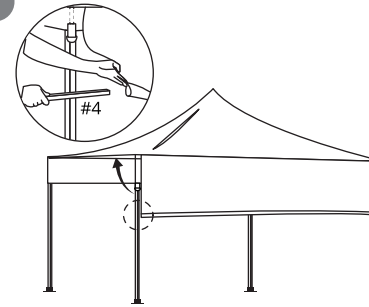

Insert the connected awning pole through the canopy fabric.

3

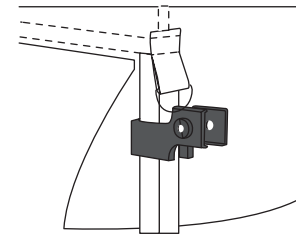

Attach the plastic parts to the leg poles.

4

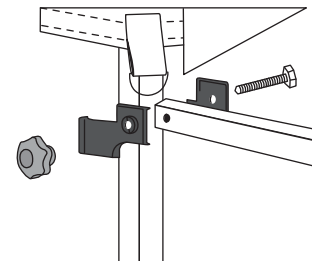

Use screws to connect the canopy support pole to the awning pole.

Teileliste

#A X1



Rahmen (Details siehe unten)

#B X1



Dachabdeckung

#C-1 X1



Seitenwand

#C-2 X2

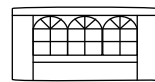

Seitenwand mit Fenster

#D X1



Rolltasche

#E X4



Befestigungsseil

#F X4



Sandsack

#G X8



Hering

#4 X1 Satz
(Männliche Stange &
weibliche Stange)

Markisenstange

#5 X2



Einzelne Markisenstützstange

#7 X1 Packung (Drehschraube & Beinklemme*2)

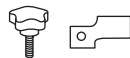

Kunststoffverbinder

Montageanleitung

1

Nehmen Sie den vormontierten Rahmen heraus, fassen Sie die beiden äußeren Beine, heben Sie den Rahmen leicht vom Boden ab und ziehen Sie ihn dann nach hinten auf.

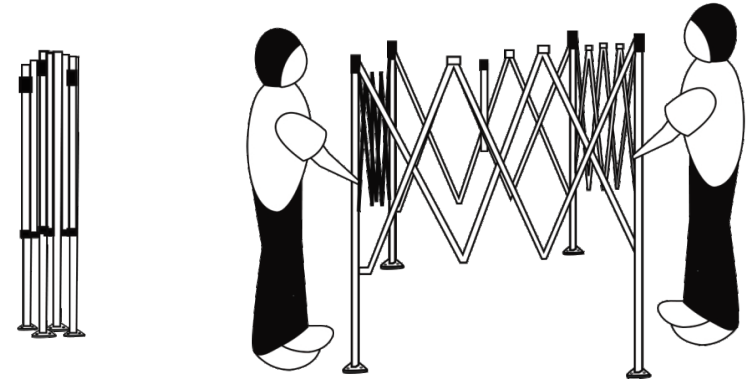

2

Befestigen Sie die Dachabdeckung am Rahmen und klappen Sie den Rahmen dann vollständig auf.

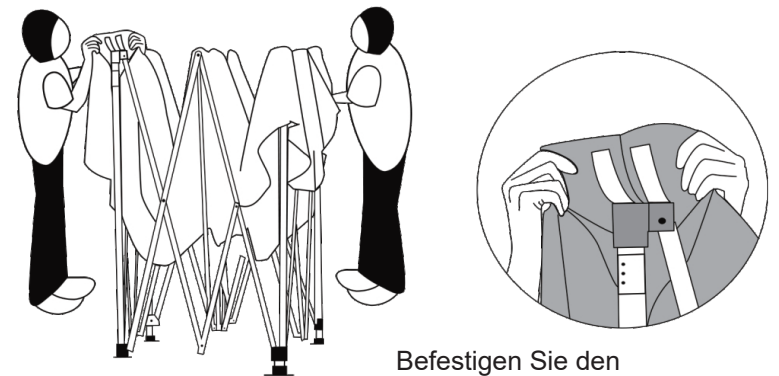

Befestigen Sie den Klettverschluss an der Abdeckung am Klettverschluss an jedem Beinpfosten.

3

Verriegeln Sie die Bein­stangen, indem Sie die Quer­stangen nach oben drücken, bis Sie die oberen Knöpfe einrasten hören.

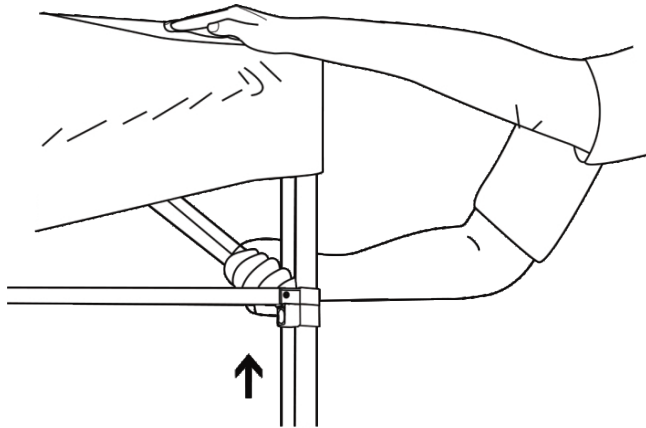

4

Befestigen Sie die Markise mit Klettverschluss an der Abdeckung.

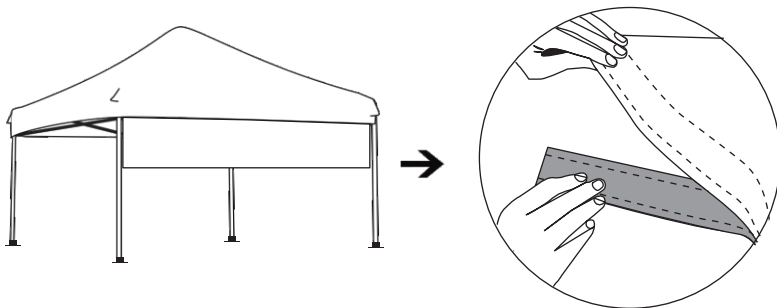

Markisenmontage

1

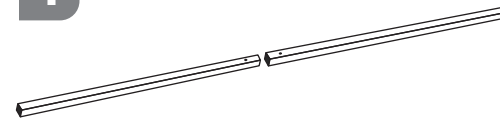

Verbinden Sie die Markisen­stange.

2

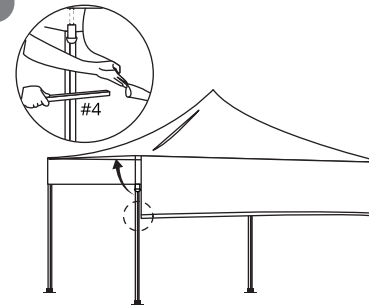

Führen Sie die verbundene Markisen­stange durch den Baldachinstoff.

3

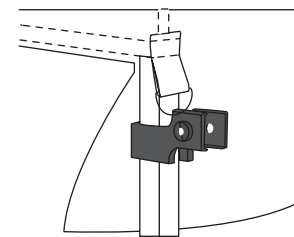

Befestigen Sie die Kunststoffteile an den Bein­stangen.

4

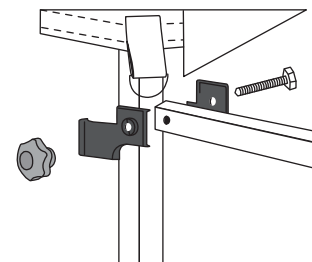

Verbinden Sie die Baldachinstütz­stange mit Schrauben mit der Markisen­stange.

Liste des Pièces

#A X1



Cadre (Voir Détails Ci-dessous)

#B X1



Toiture

#C-1 X1

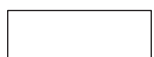

Paroi latérale

#C-2 X2

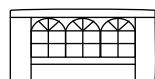

Paroi latérale avec fenêtre

#D X1



Sac à roulettes

#E X4



Corde d'attache

#F X4



Sac de sable

#G X8



Piquet

#4 X1 jeu (Poteau mâle & Poteau femelle)



Poteau d'auvent

#5 X2



Poteau de support d'auvent à une aile

#7 X1 paquet (Vis autotaraudeuses & Supports de pied *2)

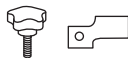

Connecteur en plastique

Instructions d'Installation

1

Retirez le cadre pré-assemblé, saisissez les deux pieds extérieurs, soulevez légèrement le cadre du sol, puis ouvrez-le en reculant.

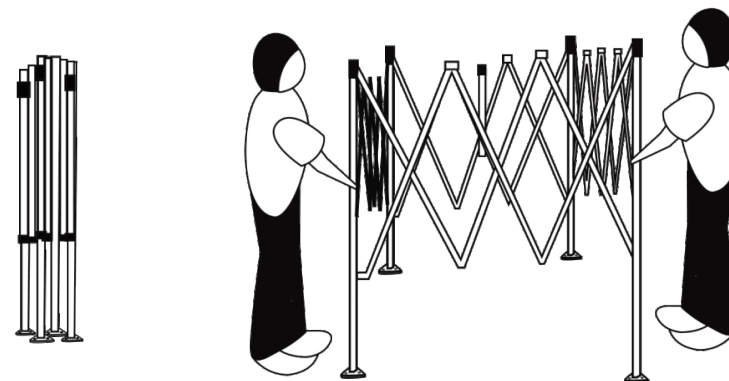

2

Fixez la couverture de toit au cadre, puis déployez complètement le cadre.

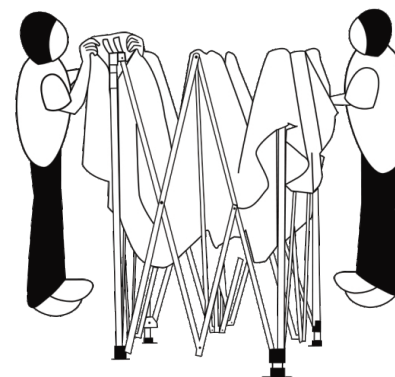

Fixez le velcro de la housse au velcro de chaque poteau de jambe.

3

Verrouillez les poteaux en poussant les barres transversales vers le haut jusqu'à entendre le clic des boutons supérieurs.

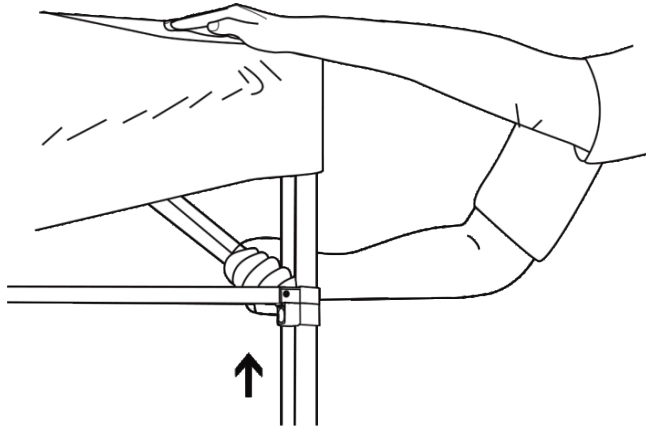

4

Fixez l'auvent à la housse à l'aide de velcro.

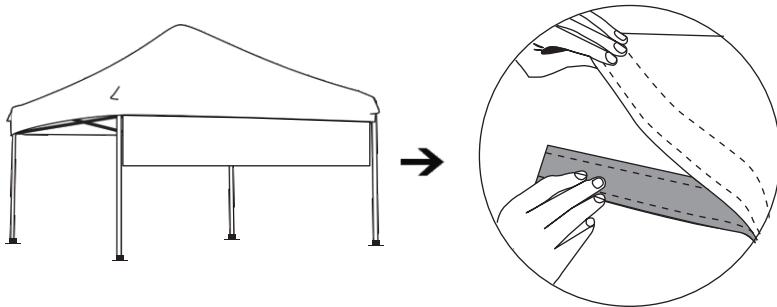

Installation du store :

1

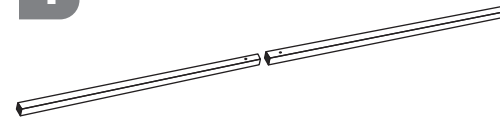

Fixez le mât du store.

2

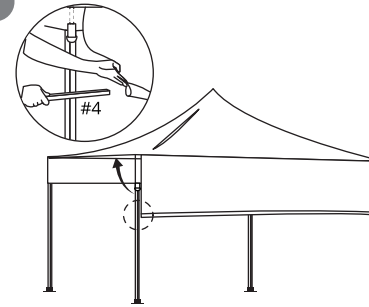

Insérez le mât connecté dans la toile.

3

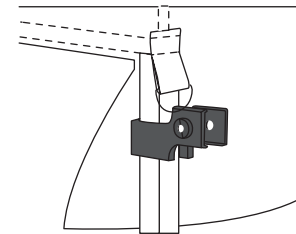

Fixez les pièces en plastique aux pieds.

4

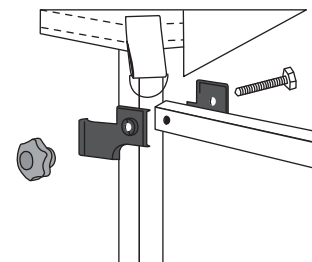

Utilisez des vis pour fixer le mât de support du store au mât.

Lista de Piezas

#A X1



Marco (Vea detalles más abajo)

#B X1



Cubierta de techo

#C-1 X1

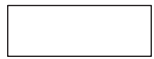

Pared lateral

#C-2 X2

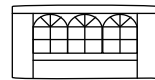

Pared lateral con ventana

#D X1



Bolsa enrollable

#E X4



Cuerda de amarre

#F X4



Saco de arena

#G X8



Estaca

#4 X1 juego (Poste macho & poste hembra)



Poste de toldo

#5 X2



Poste de soporte de toldo de una sola ala

#7 X1 paquete (Tornillo de rosca & Campamento de patas*2)

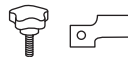

Conector de plástico

Instrucciones de Instalación

1

Saque el armazón premontado, sujete las dos patas exteriores, levante ligeramente el armazón del suelo y, a continuación, tire del armazón hacia atrás para abrirlo.

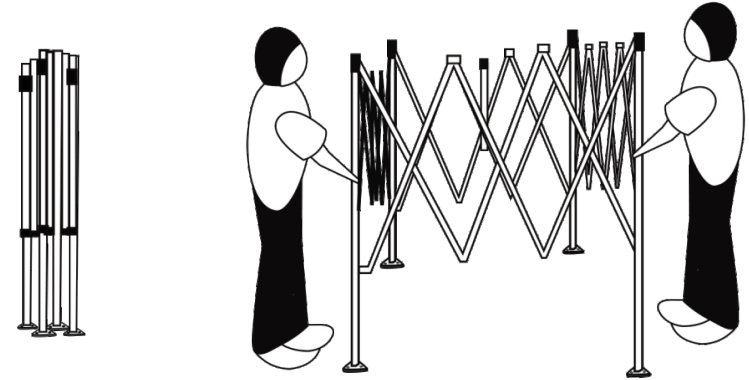

2

Fije la cubierta del techo al armazón y despléguelo por completo.

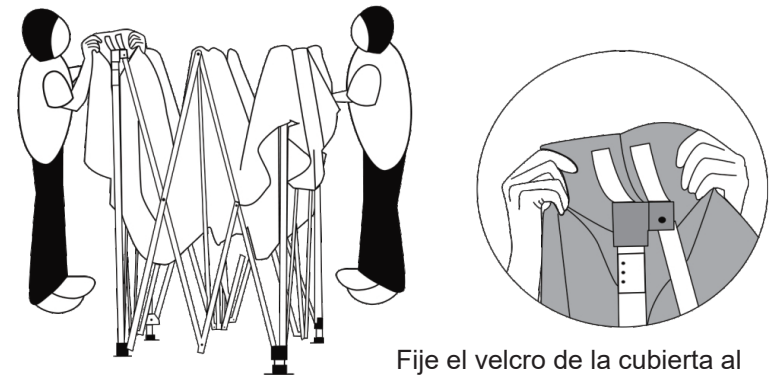

Fije el velcro de la cubierta al velcro de cada poste de las patas.

3

Bloquee los postes de las patas empujando hacia arriba los travesaños hasta que oiga el clic de los botones superiores.

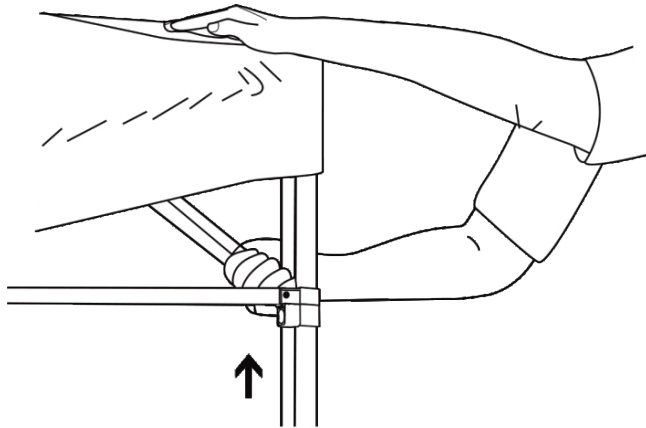

4

Fije el toldo a la cubierta utilizando el velcro.

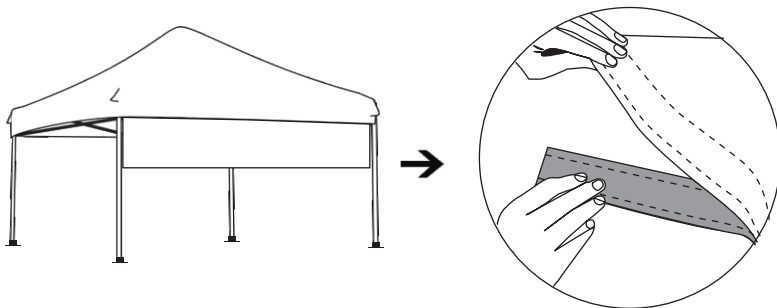

Instalación del toldo:

1

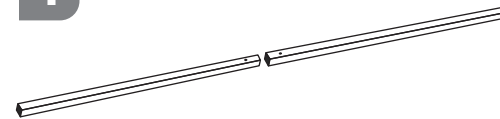

Conecte el poste del toldo.

2

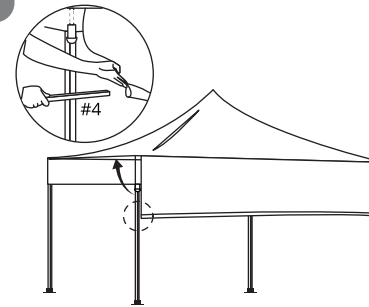

Inserte el poste del toldo conectado a través de la tela del toldo.

3

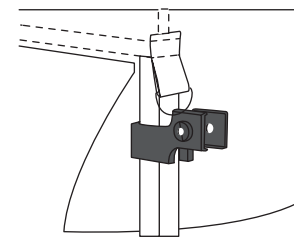

Fije las piezas de plástico a los postes de las patas.

4

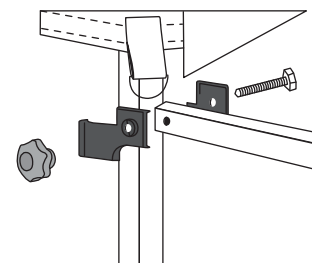

Utilice tornillos para conectar el poste de soporte del toldo al poste del toldo.

Elenco Parti

#A X1



Telaio (vedi dettagli sotto)

#B X1



Copertura del tetto

#C-1 X1

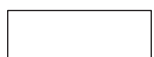

Parete laterale

#C-2 X2

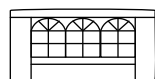

Parete laterale con finestra

#D X1



Borsa con rotelle

#E X4



Corda di fissaggio

#F X4



Sacco di sabbia

#G X8



Picchetto

#4 X1 set (Palo maschio & palo femmina)



Palo per tenda da sole

#5 X2



Palo di sostegno per tenda da sole a ala singola

#7 X1 confezione (Viti a testa cilindrica & Piedini ammortizzanti*2)

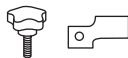

Connettore in plastica

Istruzioni di Montaggio

1

Estrarre il telaio preassemblato, afferrare le due gambe esterne, sollevare leggermente il telaio da terra, quindi aprire il telaio mentre si fa un passo indietro.

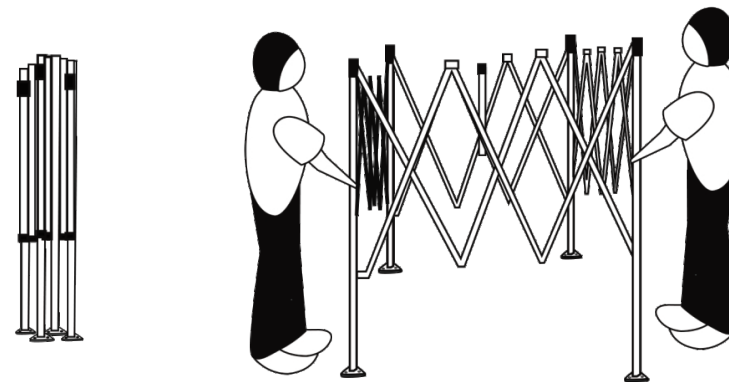

2

Fissare la copertura del tetto al telaio, quindi aprire completamente il telaio.

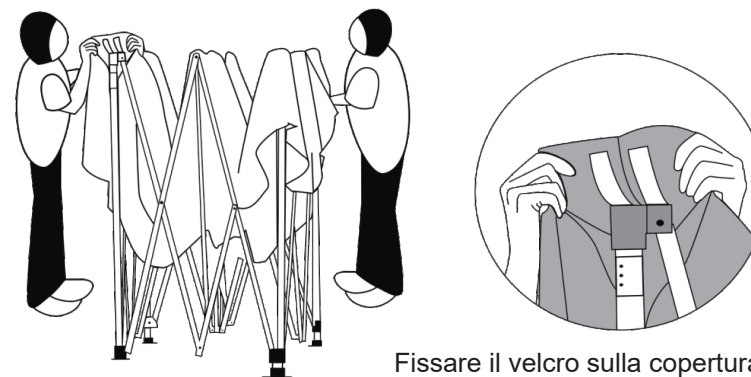

Fissare il velcro sulla copertura al velcro su ciascun palo delle gambe.

3

Bloccare i pali delle gambe spingendo verso l'alto le barre trasversali fino a sentire il clic dei pulsanti superiori.

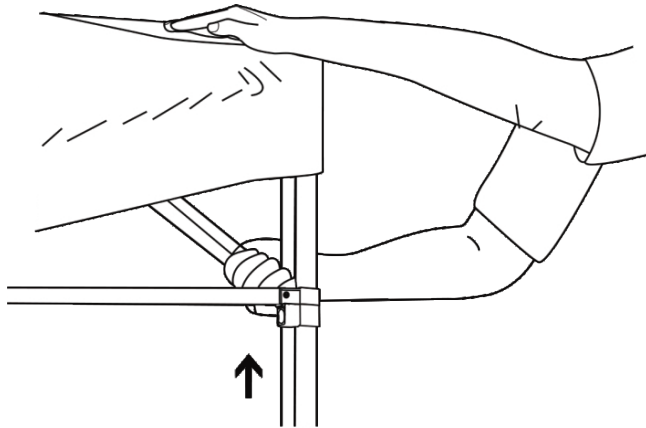

4

Fissare la tenda alla copertura utilizzando il velcro.

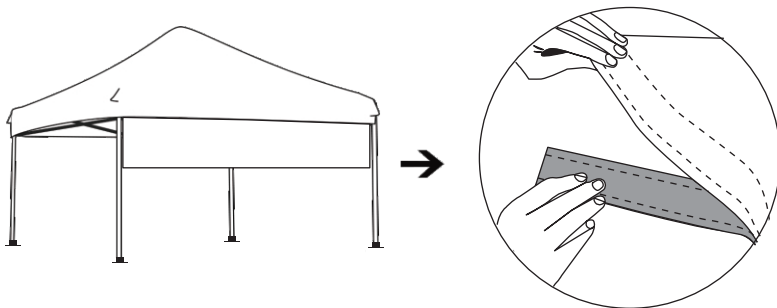

Installazione di tende da sole

1

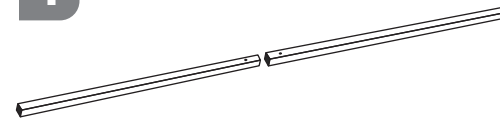

Collegare il palo della tenda da sole.

2

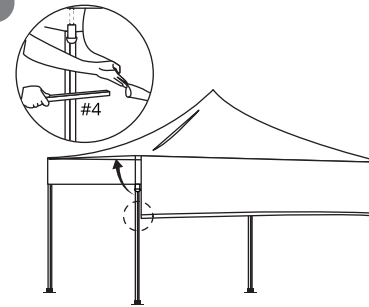

Inserire il palo della tenda da sole collegato attraverso il tessuto del baldacchino.

3

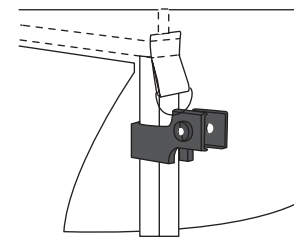

Fissare le parti in plastica ai pali delle gambe.

4

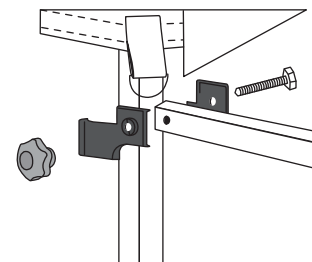

Utilizzare le viti per collegare il palo di supporto del baldacchino al palo della tenda da sole.

Lista części

#A X1



Rama (szczegóły poniżej)

#B X1



Pokrywa dachu

#C-1 X1

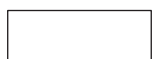

Ściana boczna

#C-2 X2

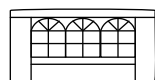

Ściana boczna z oknem

#D X1



Torba na kółkach

#E X4



Lina mocująca

#F X4



Worek z piaskiem

#G X8



Kolek

#4 X1 zestaw (pręt zewnętrzny i wewnętrzny)



Słup markizy

#5 X2



Pojedynczy drążek podtrzymujący markizę

#7 X1 opakowanie (śruba obrotowa i zacisk na nogę*2)

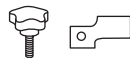

Łącznik z tworzywa sztucznego

Instrukcja montażu

1

Zdejmij wstępnie zmontowaną ramę, chwyć dwie zewnętrzne nogi, unieś lekko ramę z podłogi, a następnie pociągnij ją do tyłu.

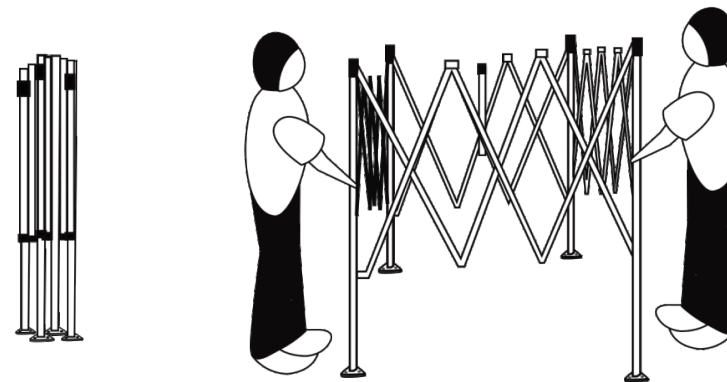

2

Przymocuj pokrywę dachu do ramy, a następnie całkowicie rozłóż ramę.

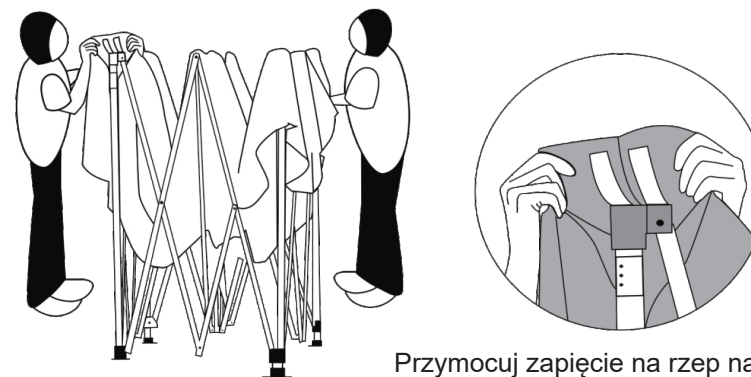

Przymocuj zapięcie na rzep na pokrywie do zapięcia na rzep na każdym słupku nogi.

3

Zablokuj słupki nóg, popychając poprzeczki do góry, aż usłyszysz kliknięcie górnych przycisków.

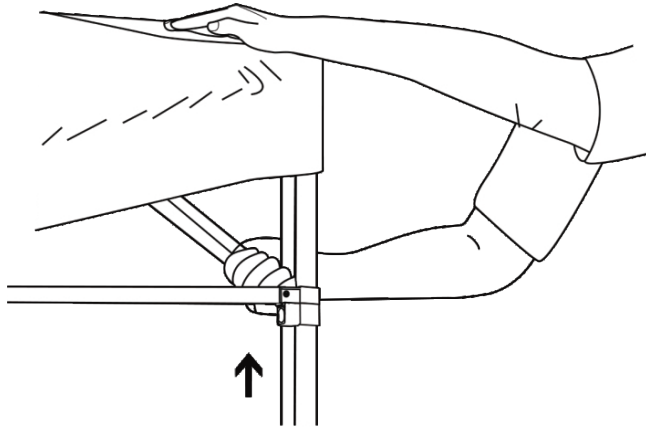

4

Przymocuj markizę do poszycia za pomocą rzepów.

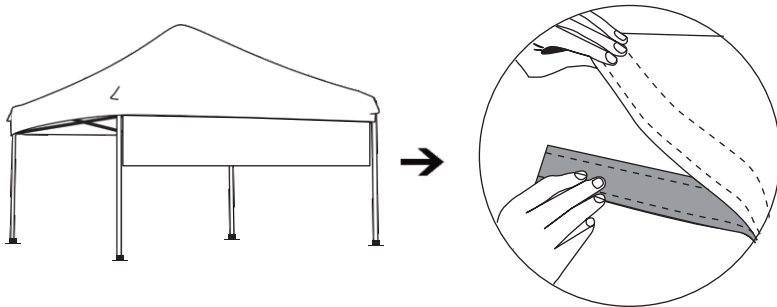

Instalacja markizy

1

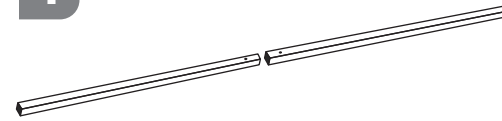

Podłącz drążek markizy.

2

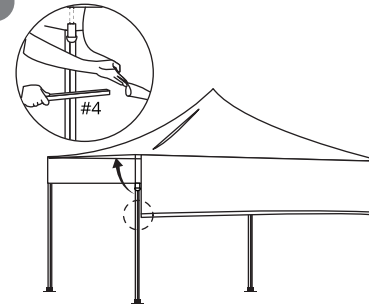

Poprowadź podłączony drążek markizy przez tkaninę zadaszenia.

3

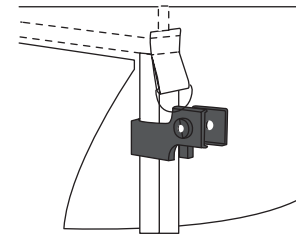

Przymocuj plastikowe części do słupków nóg.

4

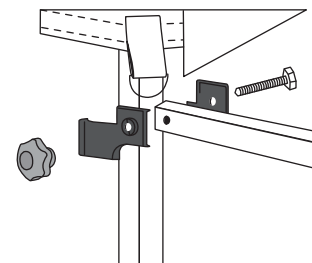

Podłącz słup podtrzymujący markizę do słupa markizy za pomocą śrub.

Onderdelenlijst

#A X1



Frame (Zie onderstaande details)

#B X1



Dakbedekking

#C-1 X1

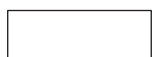

Zijwand

#C-2 X2

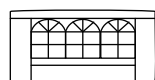

Zijwand met raam

#D X1



Rolzak

#E X4



Bindtouw

#F X4



Zandzak

#G X8



Steek

#4 X1 set (Mannelijke paal & vrouwelijke paal)



Luifelstok

#5 X2



Enkele luifelsteunstok

#7 X1 pak (Twist-type schroef & Been kamp*2)

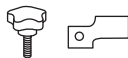

Kunststof verbindingstuk

Montage-instructie

1

Neem het voorgemonteerde frame uit, pak de twee buitenste poten vast, til het frame iets van de grond en trek het frame open terwijl u achteruit stapt.

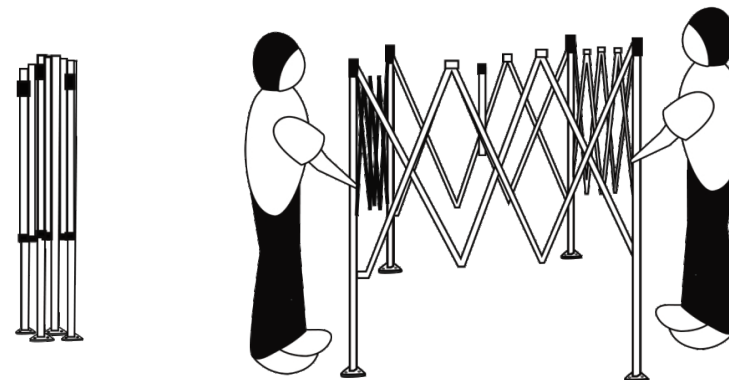

2

Bevestig de dakbedekking aan het frame en vouw het frame volledig uit.

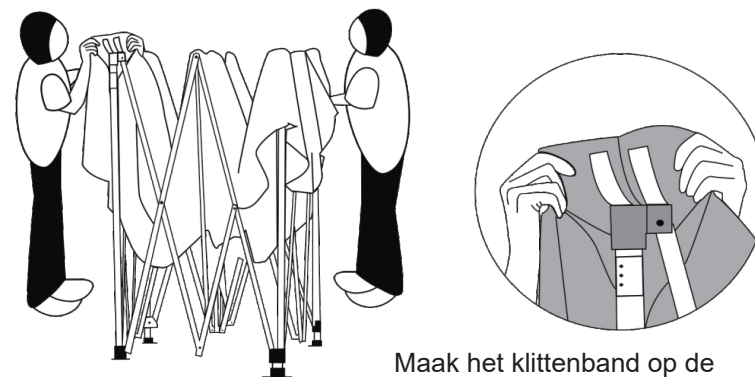

Maak het klittenband op de cover vast aan het klittenband op elke pootstang.

3

Vergrendel de pootstokken door de dwarsliggers omhoog te duwen totdat u de bovenste knoppen hoort klikken.

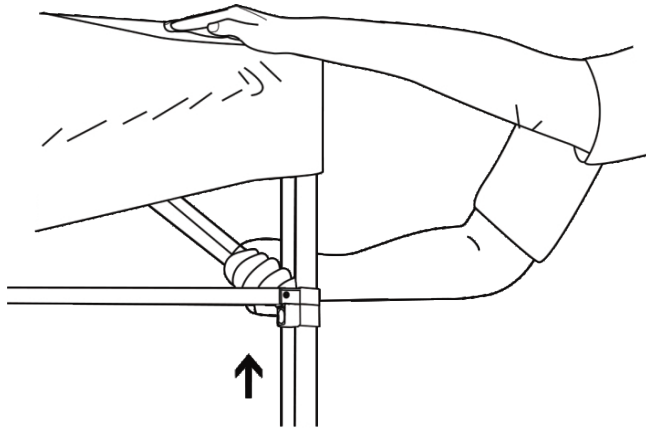

4

Bevestig de luifel aan de cover met klittenband.

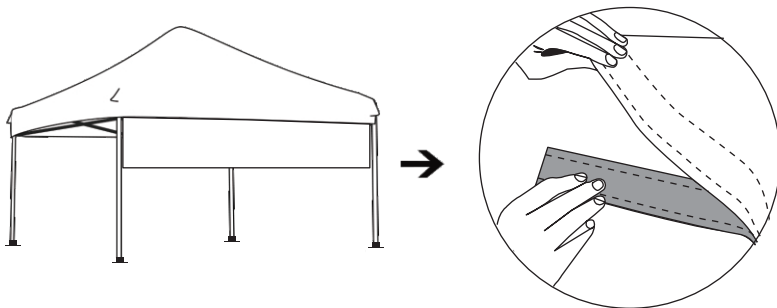

Installatie van de luifel:

1

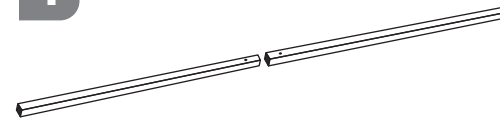

Sluit de luifelstok aan.

2

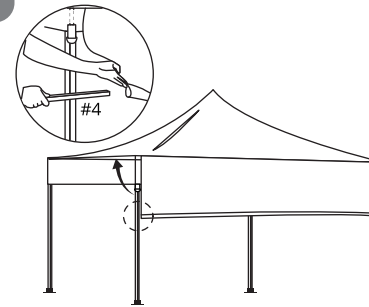

Steek de aangesloten luifelstok door het luifeldoek.

3

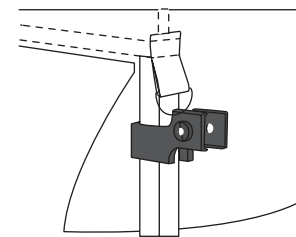

Bevestig de plastic onderdelen aan de luifelstokken.

4

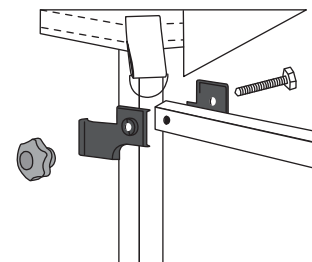

Gebruik schroeven om de luifelstang aan de luifelstok te bevestigen.